

### Also

#### IN THIS ISSUE

	<i>Page</i>
OPERATION OF THE VARIAC IN OIL . . .	4
CHECKING ANTENNA POWER WITH THE TYPE 726-A VACUUM TUBE VOLTMETER	6

## TWO NEW INDUSTRIAL STROBOSCOPES

● THE EDITOR OF A WELL-KNOWN industrial magazine remarked, not long ago, that the stroboscope held more promise for future usefulness to industry than any other instrument in the mechanical field. This opinion is well borne out by the multiplicity of uses to which General Radio stroboscopes have been applied. Manufacturers of such

diverse products as streamlined trains and tin cans use stroboscopes to make better products and to lower production costs.

The two new General Radio stroboscopes will undoubtedly develop still more applications. These new instruments, TYPE 631-B Strobotac and TYPE 648-A Strobolux, embody a number of improvements in both design and construction over previous models.

FIGURE 1. The Strobotac (left) and the Strobolux (right) with connecting cables.

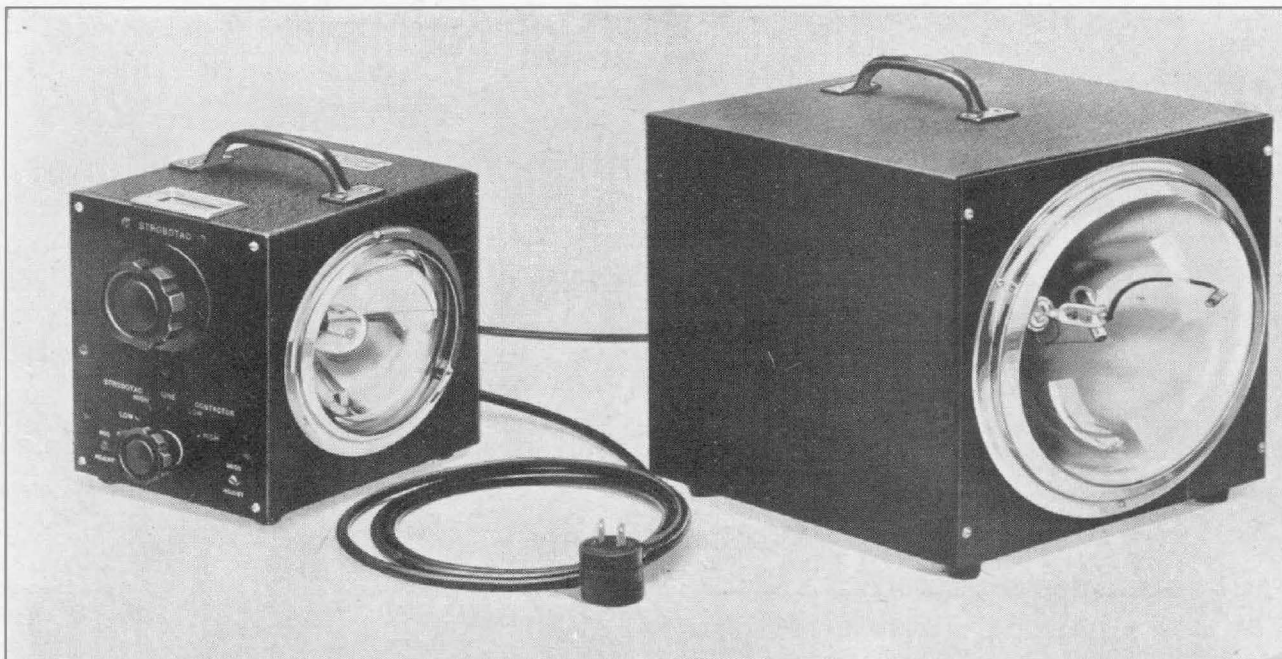



FIGURE 2. The controls and the scale of the Strobotac are arranged for maximum convenience. When the instrument is held in the left hand, as shown, the right hand is used to adjust the speed, which is read directly from the scale on the top of the case.

## STROBOTAC

The Strobotac, TYPE 631-B, is basically the same as its predecessor, TYPE 631-A\*, but improved performance and greatly increased convenience of operation make it a much better instrument. Greater accuracy of speed measurement, lighter weight, more easily read scale, more convenient location of controls — these are the features of the new instrument.

The unique scale standardization system used with the Strobotac and the increased oscillator stability in the new design make possible an accuracy of  $\pm 1\%$  for speed measurements. This accuracy is obtainable when the Strobotac is standardized in terms of a frequency-controlled power line, i.e., one on which synchronous electric clocks can be op-

\* "A New Stroboscope for Speed Measurements," *Experimenter*, August, 1935.

erated. The standardization adjustment is explained in Figure 4.

Although the accuracy specification of  $1\%$  brings the Strobotac into the class of precise tachometers, still better accuracy, often as good as  $0.1\%$ , can be obtained over small scale intervals, by standardizing the scale at two points in the range where speed measurements are to be made. The trimmers, or scale adjustment controls, are accessible from the side of the instrument.

The speed scale covers the same range as that of the old model, 600 to 14,400 rpm. Two ranges are provided, one of which is approximately four times the other. The drum-type scale, shown in Figure 3, is conveniently located on the top of the instrument. Scale graduations are in black on a translucent material, behind which a lamp is mounted. The flashing speed controls are located on the side of the case and are so arranged that, when the instrument is held in the left hand, the speed can be controlled by the right hand, and speed can be read from the top.

FIGURE 3. The scale of the Strobotac is graduated in revolutions per minute for speed measurement. The total range of 600 to 14,400 rpm is covered in two bands. The lower band extends from 600 to 3600 rpm, the upper from 2400 to 14,400 rpm. The scale can be read to better than  $0.5\%$  over most of its range.

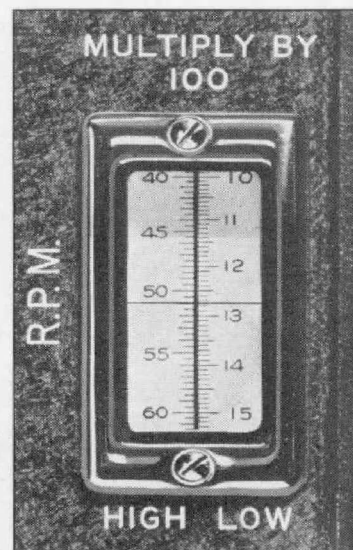

Although the over-all size of the Strobotac has not been changed, the weight has been decreased by  $25\%$ . The total weight is now but 10 pounds.

The Strobotac is provided with a jack for connection to the Strobolux, described below.

### STROBOLUX

The new TYPE 648-A Strobolux supersedes the TYPE 548-B Edgerton Stroboscope. It consists of an a-c power supply and lamp, capable of supplying about 100 times as much illumination as the Strobotac. No means for controlling the flashing rate is provided in the Strobolux. Flashing impulses are obtained from the Strobotac\*, and hence the flash control may be (1) the Strobotac oscillator, (2) the a-c power line, or (3) an external oscillator or contactor.

\* The older TYPE 631-A Strobotac can be used to flash the Strobolux if a jack for making the connection is installed. This installation will be made without charge if a Strobolux is purchased.

The Strobolux is intended for use in those applications where large areas must be illuminated, or where strong background lighting exists. Its upper speed limit is somewhat less than that of the Strobotac and is about 6000 flashes per minute.

A particularly important application of the Strobolux is in taking high-speed single-flash photographs. With large-aperture lenses and the new high-speed films, excellent pictures of areas of about one square foot are possible. Events in transient or non-repetitive motion can be recorded in this way as easily as can those in cyclic motion.

— C. E. W.

**FIGURE 4.** Showing the operation of the standardizing system. The reed is driven electromagnetically from the a-c line, and it vibrates at a frequency of 7200 per minute when the line frequency is 60 cycles. When the flashing rate of the Strobotron is equal to, or a submultiple of, the reed frequency, a single stationary image of the reed will be seen. The procedure in standardizing is to set the speed control at a submultiple of 7200 at the low end of the scale and adjust the LOW trimmer until a stationary reed image is seen, then to set the scale to a submultiple at the high end, adjust the HIGH trimmer for a stationary pattern. The speeds used are 900 and 3600 on the low scale, 3600 and 14,400 on the high scale. At 14,400 a double image will be seen because the lamp flashes twice for each vibration of the reed.

A stationary pattern of one or more images can be obtained at any scale setting where the ratio of flash speed and reed speed is an integer or an integral fraction. If only one- and two-image patterns are used, twenty-one such points will be found on the low scale alone. Consequently, for any given small speed range, a standardizing point can usually be found at each end of the range. This results in an extremely high accuracy of measurement over small ranges.

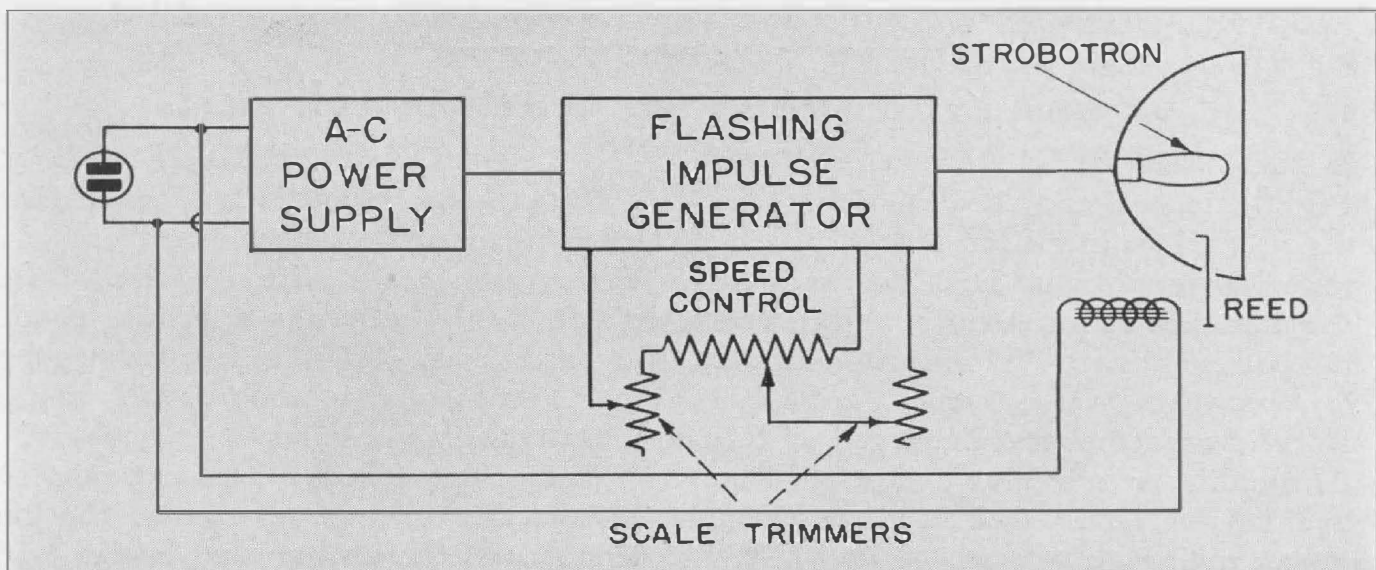

## TYPE 631-B STROBOTAC SPECIFICATIONS

**Range:** The fundamental range of flashing speed is from 600 to 14,400 per minute. The speed is read directly from a scale graduated in rpm. By using multiples of the flashing speed, the range of measurement can be extended above 50,000 rpm and, by multiple images, speeds somewhat below 600 rpm can be measured. At very low speeds, a darkened room should be used.

**Accuracy:**  $\pm 1\%$  of the dial reading above 900 rpm when the Strobotac is standardized in terms of a frequency-controlled power line. Controls for this standardization adjustment are provided.

**Duration of Flash:** Between 5 and 10 microseconds.

**Power Supply:** 115 volts, 60 cycles. Prices for operation from lines of other voltages and frequencies will be quoted on request.

**Power Input:** 25 watts.

**Vacuum Tubes:** One TYPE 631-P1 Strobotron, one 6X5-type and one 6N7-type are required. A complete set of tubes is furnished with the instrument.

**Mounting:** Aluminum case with carrying handle. Cord and plug for connection to the power line are included.

**Dimensions:**  $7\frac{1}{2} \times 8\frac{3}{4} \times 9\frac{7}{8}$  inches, over-all.

**Net Weight:** 10 pounds.

<i>Type</i>	<i>Code Word</i>	<i>Price</i>
631-B	BRAVO	\$95.00

## TYPE 648-A STROBOLUX SPECIFICATIONS

**Range:** Up to 100 flashes per second (6000 per minute). Single flashes for photography can also be obtained.

**Accuracy:** The accuracy is that of the source controlling the flashing speed. See specifications for TYPE 631-B Strobotac.

**Duration of Flash:** 10 to 15 microseconds.

**Power Supply:** 115 volts, 60 cycles.

**Power Input:** 150 watts, maximum.

**Vacuum Tube:** One 5Z3-type vacuum tube

and one 648-P1 lamp are required. Both are supplied with the instrument.

**Accessories Required:** Must be used with TYPE 631-B Strobotac.

**Mounting:** The complete assembly is housed in a sheet metal case. The detachable lamp and its 9-inch reflector are mounted on one side, the power supply on the other. Cables for connection to the power line and to the Strobotac are supplied.

**Dimensions:**  $13 \times 11\frac{1}{8} \times 13\frac{1}{8}$  inches, over-all.

**Net Weight:** 25 pounds.

<i>Type</i>	<i>Code Word</i>	<i>Price</i>
648-A	SCALY	\$175.00

General Radio stroboscopes are manufactured under designs and patent applications of Harold E. Edgerton, Kenneth J. Germeshausen and Herbert E. Grier.

## OPERATION OF THE VARIAC IN OIL

● **USERS IN THE CHEMICAL INDUSTRIES** have found it desirable to immerse Variacs in oil for the purposes of reducing explosion hazards, reducing maintenance requirements, and increasing power ratings. Oil immersion, in fact, is advantageous wherever a Variac must work in an atmosphere charged with inflammable or corrosive gases, or whenever it is necessary to exceed the normal power rating.

### EXPLOSION PROOFING

Under some conditions of operation, sparking occurs when the brushes of a Variac pass from wire to wire of the winding. The oil tends to reduce sparking and, by excluding inflammable gases from the vicinity of the brushes, makes harmless any sparks which may occur.

Obviously, for the greatest possible safety, the oil level should be checked frequently. Mounting the Variac with

the brush end at the bottom of the oil tank insures that the brushes will remain covered unless the oil level becomes excessively low.

It should be pointed out that oil immersion does not remove all possibility of explosion. Ordinary transformer oils evaporate slowly, and their vapors can be ignited by external causes. Since the flash point of transformer oils is about 130° C. (240° F.), there is no chance of spontaneous ignition except in cases of prolonged, very high overloads.

Fireproof oils are available, but must not be used with Variacs because they destroy the insulation of the windings.

### REDUCED MAINTENANCE

When a Variac is used in an atmosphere of corrosive gases or is subject to spattering with corrosive liquids, the oil protects it, prolongs its life, and reduces the amount of servicing required. Even in ordinary uses the oil serves as a lubricant and keeps the winding bright and smooth with less cleaning than would otherwise be needed. The reduced sparking under heavy loads prolongs the life of the brushes.

### INCREASED RATING

The maximum safe current which can be drawn from a Variac is, in general, limited by the rate at which heat can be carried away from the brushes. Surrounding the Variac with oil greatly increases the rate of cooling of the brushes and permits a corresponding increase in the maximum current. The oil also increases the cooling of the Variac as a whole and makes possible a moderate increase in the rated current.

The advantages of oil cooling are most striking in the case of the TYPE 100 Variacs where the brush limitation is greatest.

### EXAMPLE

The following table gives an approximate idea of the effect of oil cooling, for the case of a TYPE 100-Q\* Variac. The Variac was mounted in a cylindrical steel tank, 9 inches in diameter and 10 inches deep, and the brush end was about 1/8 inch from the bottom of the tank. Somewhat less than two gallons of oil were required to fill the tank 9 inches deep. Space must be allowed for expansion of the oil as it warms up.

	100-Q Variac in Air	100-Q† Variac in Oil
Rated Current	18 amp.	22 amp.
Maximum Current	18 amp.	35 amp.
Rated Power	2000 v. a.	4000 v. a.

Similar, though less striking, increases in safe power output can be expected with other types. The addition of water cooling by means of a cooling coil in the oil as close as possible around the Variac will of course permit further increases in power rating.

If the TYPE 100-K or TYPE 100-L Variac is used in oil, the brushes and brush springs must be replaced by those now used in the TYPE 100-Q and TYPE 100-R Variacs. The new brushes have flexible leads for connection to the radiator. Without these flexible leads the oil makes the connection between brushes and radiator uncertain and excessive heating may result, nullifying the advantages of the oil coating.

### REPLACEMENTS

	Type 100-K	Type 100-L
Brushes	2—type 100-321	2—type 100-322
Brush	{ 1—type 100-345A	1—type 100-345A
Springs	{ 1—type 100-345B	1—type 100-345B

— STEPHEN A. BUCKINGHAM

\*TYPE 100-● and TYPE 100-R Variacs are new models replacing TYPE 100-K and TYPE 100-L. The new models have approximately the same ratings as the old, but furnish output voltages greater than the input line voltage.

† Comparable results can be obtained with TYPE 100-K.

## CHECKING ANTENNA POWER WITH THE TYPE 726-A VACUUM-TUBE VOLTMETER

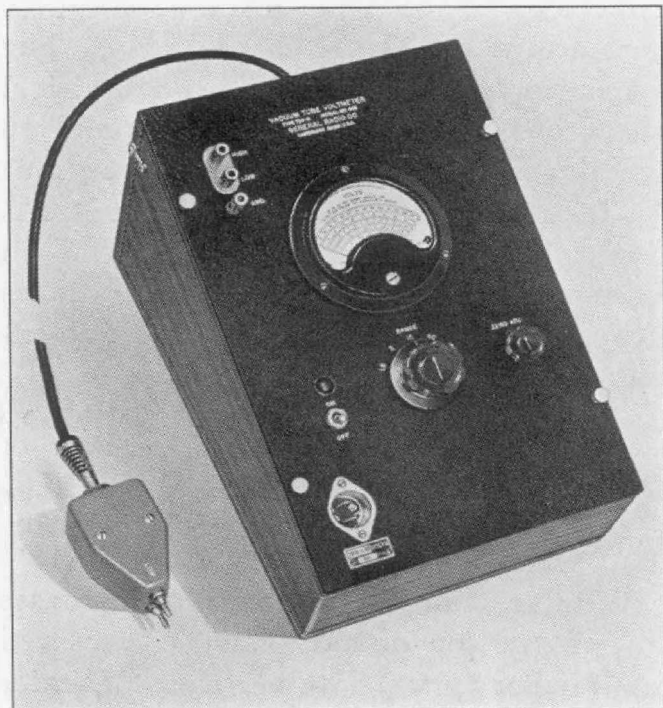

● **POWER, AT RADIO FREQUENCIES**, is ordinarily computed from measured currents and resistances because no generally accepted method of direct measurement has yet been discovered. Unfortunately, the indirectness of the method makes it necessary to measure current and resistance with much greater accuracy than that required in the value of power because the errors may accumulate in the computation. Even if the current and resistance are both measured to an accuracy of  $\pm 1\%$ , for instance, the computed power may be in error by as much as  $3\%$ .

Considerable stress has been laid upon improving the technique of making antenna resistance measurements at broadcast frequencies in recent years, and methods and circuits have been developed that are rapid and reliable. Current measurements have not received as much detailed attention, probably because they are, in general, much more

easily made than impedance measurements, and because the specified accuracy of the meters themselves is usually high. Errors in the current measurements, however, enter twice into the computed power since the current enters as the square. In order to take full advantage of the accuracy of resistance measurement that can be obtained, it has consequently been found desirable in the field to be able to obtain an accurate check on the antenna current.

Experience in the measurement of antenna impedance has emphasized the desirability of using two or more dissimilar methods, when possible, to eliminate the chance of neglecting some significant error specifically associated with one of the methods. The measurement of current with two different types of instruments is desirable for the same reason.

With capacitive shunts, the TYPE 726-A Vacuum-Tube Voltmeter can be used as an ammeter that requires relatively little power<sup>1</sup>. The antenna ammeter can be checked against the shunted voltmeter as shown in Figure 1.

This method is particularly useful, first, because the voltmeter-condenser combination is small and can be connected in circuit at the point where the antenna impedance is measured and, second, because the check can be made at the operating frequency.

The principal reasons for lower accuracy in the ammeter than in the voltmeter-condenser combination are that skin effect in the heater of thermocouple meters designed for relatively large currents is often appreciable, and that shunting capacitances in the wiring

<sup>1</sup>"The TYPE 726-A Vacuum-Tube Voltmeter as a Radio-Frequency Ammeter," *General Radio Experimenter*, Volume XIII, Nos. 3 and 4, August-September, 1938.

between the meter and the point at which the antenna impedance is measured often by pass current, which is read by the meter but which does not enter the antenna<sup>2</sup>. The capacitance of the voltmeter-condenser combination, on the other hand, can be measured at the operating frequency with the equipment used to measure the antenna impedance, and the frequency error of the voltmeter is completely negligible at broadcast frequencies.

It should be recognized that the condenser of Figure 1 must carry the total

<sup>2</sup> The shunting capacitance is particularly important if an extension meter is used with a shielded lead from the thermocouple. It should be emphasized that the shield should be connected to the transmitter side of the thermocouple rather than to ground or to the antenna side of the thermocouple in order to minimize the error.

current without overheating. Its capacitance is determined from the maximum reading,  $I_{max}$ , of the antenna ammeter, the maximum voltage reading,  $V_{max}$ , of the TYPE 726-A Vacuum-Tube Voltmeter, and the frequency by the expression

$$C = \frac{1}{\omega} \frac{I_{max}}{V_{max}}$$

For a 5-kw station, using a shunt-excited antenna with a 65  $\Omega$  resistive component, at a frequency of 1000 kc, for instance, a suitable value of  $C$  would be 0.01  $\mu$ f.

—D. B. SINCLAIR

## TOWARD A SILENT SUBWAY

● **THE OTHER DAY** in New York City's Eighth Avenue Subway, crowds of harassed commuters, battling for seats, were thwarted by the closed doors of a car marked "No Passengers." Inside was a group of engineers who had installed the most up to date of testing instruments in preparation for a trial express run between 59th and 125th Streets. When the train got under way, Mr. V. A. Schlenker, New York acoustical engineer, concentrated on the fluttering stylus of a recorder operating from a General Radio Sound-Level Meter. The results of this test run were of critical importance both to the subway and to the Firestone Rubber Company, for on one mile of track between 81st and 99th Streets, Central Park West, Firestone had made a trial installation of rubber tie plates, designed to reduce the noise and vibration of the trains and prevent undue transmission through the subway foundations to adjacent buildings.

These tie plates are hard rubber pads, about five inches square and one inch deep, assembled in a steel harnessing jacket and installed under the track at each tie. Should they absorb enough vibration, the pads would prolong the life of the trucks and the rails. Buildings adjacent to the subway, often receivers of transmitted vibration, would also benefit from the installation, and, more important from the commuter's point of view, the clatter, din, and sidesway of the cars would be diminished, to the great relief of the underground New Yorker's nervous system.

At fifty miles an hour, top speed, the northbound express roared up the trial run, and Mr. Schlenker noted on the sound-level record the beginning and the end of the treated mile marked off by flares of lights placed beside the track. Afterward, the sound-level record was checked accurately with the graphs of speed and acceleration. The corrected record showed that the noise in the car

was less on the rubber-studded mile. Later measurements with the sound-level meter in a west side hotel, whose foundations abut the subway opposite the installation, showed a noise reduction of twelve decibels. This represents a reduction of the subway sound in the hotel to one-quarter its former level.

The results obtained using a vibration pickup with the sound-level meter were even more revealing. The rubber installation was responsible for a three-

decibel decrease in floor vibration in a car racing ahead at fifty miles an hour, and in the steel columns supporting the northbound track there was a seven-decibel reduction. In the hotel, again, the meter registered eleven decibels of vibration improvement.

In New York's current enthusiastic campaign for lessening the city tension by eliminating unnecessary noise, the test mile along Central Park West is a forward stride. The TYPE 759-A Sound-Level Meter was the technical witness in the trial of the new development.

---

## MISCELLANY

● **COLLABORATING IN THE DESIGN** of the new Strobotac and Strobolux were H. E. Edgerton, K. J. Germeshausen, and H. E. Grier of Massachusetts Institute of Technology and H. S. Wilkins of the General Radio engineering staff.

● **IN A FORTHCOMING ISSUE** of the *Experimenter*, Dr. S. A. Buckingham will describe several new Variacs,

including the TYPES 100-Q and 100-R mentioned in his article in this issue.

● **AMONG RECENT VISITORS** to the General Radio plant were Eugenio Fubini-Chiron and Paolo Pontecorvo of the Istituto Elettrotecnico Nazionale Galileo Ferraris at Turin, Italy, and Stuart L. Bailey and Ronald H. Culver of Jansky and Bailey, Washington, D. C.

---

***T**HE General Radio EXPERIMENTER is mailed without charge each month to engineers, scientists, technicians, and others interested in communication-frequency measurement and control problems. When sending requests for subscriptions and address-change notices, please supply the following information: name, company name, company address, type of business company is engaged in, and title or position of individual.*

---

## GENERAL RADIO COMPANY

30 STATE STREET - CAMBRIDGE A, MASSACHUSETTS

BRANCH ENGINEERING OFFICES

90 WEST STREET, NEW YORK CITY

1000 NORTH SEWARD STREET, LOS ANGELES, CALIFORNIA